



Top quality requirement

Top quality requirement



HoringLih has designed high quality safety and protection products for a wide range of fire alarm systems including detectors, control panels, fire alarm components and many more. The addition of our state-of-the-art manufacturing facility enables us to maintain quality assurance as we continue to expand throughout the whole world. With our distributors serving over 50 countries, we have established a world-wide distribution network.

HoringLih has been in the Fire Alarm market for 35 years and we have built a fine reputation based on our customers' feedback. We continually bring new products into the market because HoringLih knows what customers need.

HoringLih has a long-term devotion to the fire alarm business with only one purpose –

We are concerned about people's life.





Advanced
technology and
experienced
skill

CONTENTS

01	Addressable System	QA16 Addressable Fire Alarm Control Panel -----01 QA01, QA05, QA06 Addressable Detectors -----02 QA17 Module Series -----03 QA19, QA0817 Addressable Manual Call Points -----04
05	New Series Detectors	New Series Detectors -----05 EDB01 Reflective Beam Smoke Detector -----06 Q01 Photoelectric Smoke Detector -----07 Q05 Combination Smoke and Heat Detector -----08 Q06 Heat Detector -----09 8011 Photoelectric Smoke Detector -----10 AH-0715 Combination Smoke and Heat Detector -----11 8016 Heat Detector -----12 AH-0933 Mechanical Rate of Rise Heat Detector -----13 IR-0714, IR-0814 IR Flame Detector -----14 AHMB-071 Mounting Base -----15
16	AH-031 Series Detectors	AH-031 Series -----16 AH-0311 Multi-Purpose Smoke Detector -----17 AH-0315 Multi-Purpose Smoke and Heat Detector -----18 AH-0316 Multi-Purpose Combination Heat Detector -----19 AHMB-031 Multi-Purpose Mounting Base -----20
21	UL listed Detectors	AH-0621 Photoelectric Smoke Detector -----21 AH-0625 Combination Smoke and Heat Detector -----22 AH-0626 Heat Detector -----23
24	Detectors	AH-9315 Combination Smoke and Heat Detector -----24 AHR-871 Mechanical Rate of Rise Heat Detector -----25 AH-9920 Mechanical Fixed Temperature Heat Detector -----26 AH-0014 Flame Detector -----27 AHMB Mounting Base -----28 AHMB Implanted-Type Mounting Base -----29 NQ12 Resettable Type Smoke Detector -----30
31	Residential Use Detectors	NDKA1/NDKB1 Carbon Monoxide Detector -----31 AH-0822 Gas Detector -----32 NQ3F Single Station Heat Detector -----33 NQ9F Single Station Heat Detector -----34 NQ3S Single Station Smoke Detector -----35 NQ9S Single Station Smoke Detector -----36 QA31 Single Station Smoke Detector -----37
38	Accessories	AH-03127 Electronic Sounder and Beacon -----38 AH-0817 Resettable Manual Call Point -----39 AH-0217 Manual Call Point -----40 AH-9717 Manual Call Point -----41 NQ618 Fire Alarm Bell 6" -----42 NQ418 Fire Alarm Bell 4" -----42 AH-0218 Fire Alarm Bell 6" -----43 AH-9719 Fire Indicating Lamp -----43 AH-03128 Detector Testing and Removal Device -----44 AH-07128 Detector Testing Device -----44 AH-413 Remote Indicating Lamp -----45 AH-01313 Remote Indicating Lamp -----46
47	Fire Alarm Control Panels	Vivid 32 Fire Alarm Control Panel -----47 QA12 & 5-QA12 Fire Alarm Control Panel -----48 AH-03312 Fire Alarm Control Panel -----49 QP Series Fire Alarm Control Panel -----51
52	Multi-Hazard Suppression Systems	QSP-120 Multi-Hazard Suppression Control Panel -----52 AH-03232 Manual Pull Station -----52 AH-03233 Releasing Indicator -----52



QA Series

Addressable Fire Alarm Systems

QA series can be in single or 32 loops network configurations. This system is designed for all applications with advantages of easy installation, fast and precise detection and simple maintenance. Friendly HL Fire Tool software saves your time from programming. Reliable QA series definitely meets your demands for safety.



QA16
Addressable Fire
Alarm Control Panel



QA01
Addressable Photoelectric
Smoke Detector



QA05
Addressable Combination
Smoke & Heat Detector



QA06
Addressable Heat Detector

Addressable Fire Alarm Control Panel

Characteristics

- Each loop can connect up to 250 addressable devices. Maximum networking are 32 loops and total addressable points are 8000.
- Large LCD screen (40 x 15 lines) allows more events to be displayed on the same screen.
- Loop device can be set up to be temporarily isolated.
- Individual loop module test feature to save time on panel test.
- On-board Self-test feature for simulating alarm output.
- Easy system programming through PC to panel.
- Events log can store up to 2030 events.
- Specification Optional thermal printer that can printout complete panel status.

Addressable Detectors

Characteristics

- Latching function helps to identify alarm device clearly and quickly.
- Address coding by dip switch makes the job easier.
- Magnetic test feature makes maintenance easy and simple.
- Non-loosening screws on base terminal for easy installation.
- Detector is made of high endurance, solid and colorfast Fire-proof plastic.
- Detector has passed strict EMC test, which greatly eliminates false alarms caused by interference from nearby sources.
- Dual LEDs for 360-degree visibility.

Specifications

Model	QA16
Power	220V AC 50/60Hz *Others also available
Battery Capacity	24V DC 4Ah
Charging Voltage, Current	26V DC 100~1000mA *With auto adjustment function
Zone Voltage, Current	26.5V DC 340mA
System Capacity	250 devices/1 loop *Expandable for site requirement
Exterior Resistance	Round-trip under 40Ω
Transmitting Method	Digital series transmitting
Accumulation Time	0~40 seconds *Other options available
Main Sound	85dB @1M
Material	1.6mm steel plate
Color	Pearl gray
Dimensions (mm) H x W x D	1~4 loop: 400 x 500 x 130 5~8 loop: 600 x 500 x 150

Specifications

Model	QA01	QA05	QA06
Address Coding		Binary	
Alarm Current		DC26V 6mA	
Standby Current		DC26V 850μA	
Sensitivity Setting		Comply to EN54	
Ambient Temperature		0°C ~ +50°C	
Thermal Setting	N/A	58°C	58°C
Dimensions(mm)	102(Dia.) x 48(H)	102(Dia.) x 54(H)	102(Dia.) x 46(H)
Weight	130g	130g	115g
Material		Fire-proof plastic	
Color		White	

QA Series

Addressable Fire Alarm Systems



QA Series Addressable Fire Alarm System Configuration

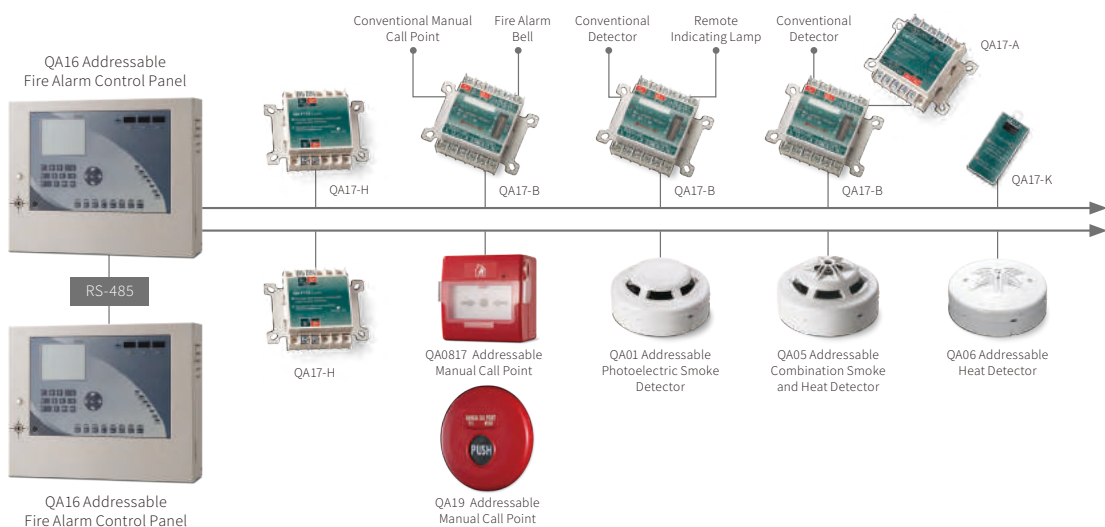

Module Series

Characteristics

- Low power consumption in monitoring mode, high stability.
- Easy installation, either single module installation or several modules installed on a special mounting bar. Implanted type gang box is available to suit the decoration design.
- The Module is designed with separate input and output contacts to decrease the difficulty of moving external wiring.
- Control Module QA17-B is designed to control input & output for all kinds of systems. (fire alarm, smoke evacuation, sprinkler, foam , winding door...etc.)
- Output module QA17-A can directly connect with power source. The output voltage from N.O. & N.C. will be the same as input voltage.
- Monitor module QA17-K is designed to monitor security condition, such as water supply, pump action ...etc.

Specifications

Model	QA17-K	QA17-B	QA17-A	QA17-H
Type	Monitor Module	Control Module	Output Module	Isolator Module
Purpose	Confirmation of external signal	Input & Output for all systems	Supply higher current such as evacuation	Isolate from control unit when external fault
System Connected	Receive activation signal from external device	Series with conventional detector	Series with QA17-B	Series with all system zone
Input Source	Activation signal	Loop signal	24VDC / 110VAC / 220VAC	Zone short circuit
Output Contacts/Load	N/A	1 in 2 out COM. N.O. N.C. 1.5A @30V DC	COM. N.O. N.C. 4A @30VDC, 2.5A @ 250VAC	N/A
EOL Resistor	10kΩ	10kΩ	N/A	N/A
Address Coding	Binary	Binary	N/A	N/A
Ambient Temp.	0°C ~ +50°C			
Material	Fire-proof plastic			
Color	Green			
Dimensions (mm) H x W x D	55 x 27 x 16		60 x 76 x 31	

Addressable Manual Call Points

Specifications

Model	QA19	QA0817
Purpose	Signal will directly sent to panel	
System Connected	Control panel zone	
Input Source	Zone signal	
Output Contacts/Load	N/A	
Address Coding	Binary	
Operating Voltage	26V DC	
Alarm Current	6mA	
Quiescent Current	850μA	
Ambient Temperature	0°C ~ +50°C	
Material	Fire-proof plastic	
Color	Red	
Dimensions(mm)	140(Dia.) x 45(H)	87.5(H) x 87.5(W) x 54(D)
Remarks	-	Protection Cover is optional

New Series Detectors

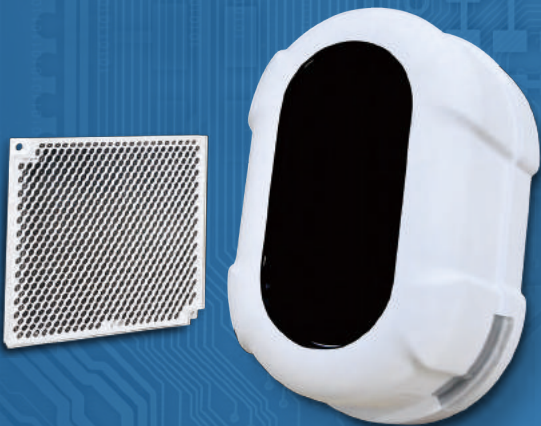

EDB01
Reflective Beam Smoke
Detector



Q01
Photoelectric Smoke
Detector



Q05
Combination Smoke and
Heat Detector



Q06
Heat Detector

EDB01

Reflective Beam Smoke Detector

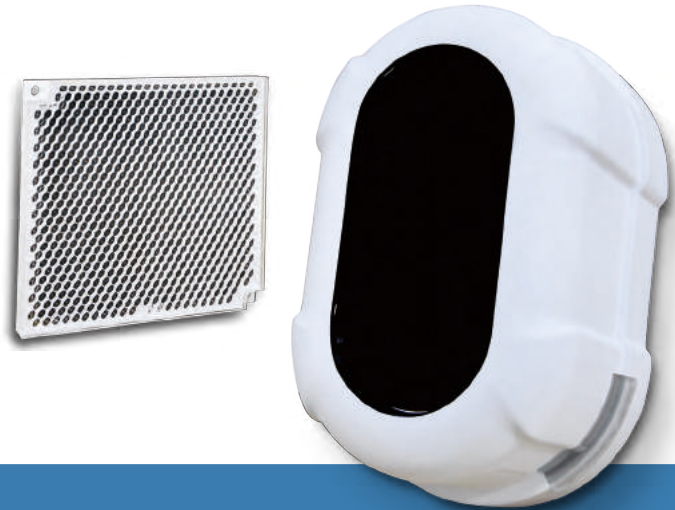

Operating Principle

The reflective beam smoke detector is a single unit comprising a transmitter and a receiver. The transmitter projects a cone shaped beam of modulated infra-red light to prisms. An alarm condition will be determined when the signal is analyzed to reach up to the settings of retention of smoke. In addition, the system is designed to be wall-mounted so that the beam will project approximately 0.3m to 0.6m below and parallel to the ceiling and the maximum lateral range is 7.5m either side of the beam. The distance between detector and the prism should be within 100m.

Features

- The detection level can be set to 18%, 25%, 35%, and 50% to suit different environments.
- Lower current consumption.
- Easy installation & Low potential voltage
- Self-alignment & Automatic contamination compensation.
- Laser-aid alignment.
- Smartphone / Tablet applications display enabled (with blue-tooth module options).
- Application Locations: Warehouses, Factory halls, Departments Stores, Activity Centers, Churches, Museums, Electric Power Stations and Industrial Sites.

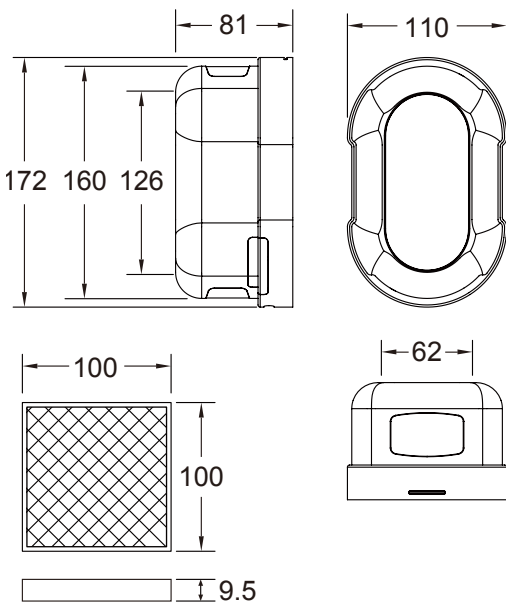

Specifications

Model	EDB01
Operating Voltage	12-30V DC
Standby Current	3~20mA
Alarm Current	20~40mA
Alarm Output	COM/NO (1A @30V DC)
Fault Output	COM/NC (1A @30V DC)
Sensitivity	18%(0.79-0.96dB), 25%(1.25dB), 35%(1.87dB), 50%(2.43-3.16dB)
Operating Range	10m to 50m use one prism 50m to 100m use four prisms
Angular Tolerance	Detector: $\pm 0.5^\circ$ / Prism: $\pm 5.0^\circ$
Ambient Temperature	-10°C ~ +55°C
Material	ABS Plastic
Color	White
Weight	350g (Detector)

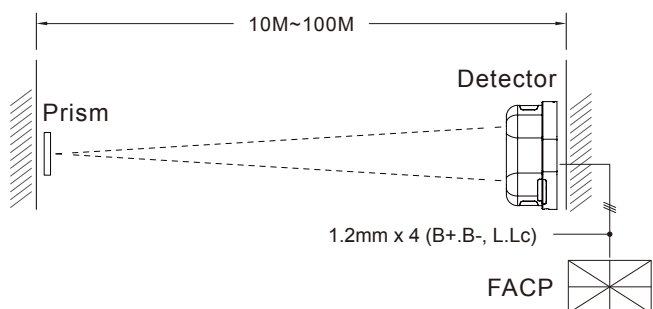



Q01

Photoelectric Smoke Detector

Characteristics

- The standard detector is 2-wire or 3-wire. For 4-wire type just add one relay output module on 3-wire base. Simple and easy module placement enables wider application and flexible stock control.
- Detector is made of high endurance, solid and colorfast Fire-proof plastic.
- Non-loosening screws on base terminal for easy installation.
- Detector has passed strict EMC test, which greatly eliminates false alarms caused by interference from nearby sources.
- Dual LEDs for 360-degree visibility. Bi-color LED, Stand-by Status: Green; Alarm Status: Red.

Specifications

Model	Q01-2	Q01-3	Q01-4
Alarm Contact	N/A	N/A	0.8A @30V DC 0.4A @125V AC
Voltage Range	12 ~ 30V DC		
Alarm Current @24V DC 470Ω	40mA	40mA	45mA
Standby Current @24V DC 470Ω	under 75μA		
Sensitivity Setting	Comply to EN54		
Ambient Temperature	-10°C ~ +55°C		
Material	Fire-proof plastic		
Dimensions	102mm(Dia.) x 48mm(H)		
Weight	130g	130g	145g
Color	White		

Effective alert area

Building Height	Area Covered
Under 4M	150 M ²
4 ~ 20M	75 M ²

Order information

Q01-2	2-wire
Q01-3	3-wire with remote indicator output
Q01-4	4-wire with relay output

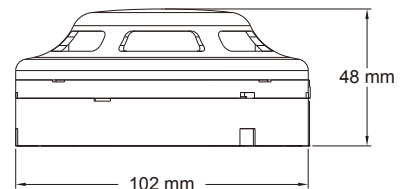

Q05

Combination Smoke and Heat Detector



Characteristics

- The standard detector is 2-wire or 3-wire. For 4-wire type just add one relay output module on 3-wire base. Simple and easy module placement enables wider application and flexible stock control.
- Detector is made of high endurance, solid and colorfast Fire-proof plastic.
- Non-loosening screws on base terminal for easy installation.
- Detector has passed strict EMC test, which greatly eliminates false alarms caused by interference from nearby sources.
- Dual LEDs for 360-degree visibility. Bi-color LED, Stand-by Status: Green; Alarm Status: Red.

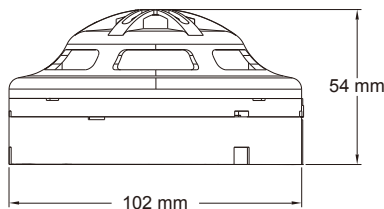

Specifications

Model	Q05-2	Q05-3	Q05-4
Alarm Contact	N/A	N/A	0.8A @30V DC 0.4A @125V AC
Voltage Range	12 ~ 30V DC		
Alarm Current @24V DC 470Ω	40mA	40mA	45mA
Standby Current @24V DC 470Ω	under 85μA		
Sensitivity Setting	Comply to EN54		
Thermal Setting	58°C		
Ambient Temperature	-10°C ~ +55°C		
Material	Fire-proof plastic		
Dimensions	102mm(Dia.) x 54mm(H)		
Weight	130g	130g	145g
Color	White		

Effective alert area

Building Height	Area Covered
Under 4M	150 M ²
4 ~ 20M	75 M ²

Order information

Q05-2	2-wire
Q05-3	3-wire with remote indicator output
Q05-4	4-wire with relay output





Q06

Heat Detector

Characteristics

- The standard detector is 2-wire or 3-wire. For 4-wire type just add one relay output module on 3-wire base. Simple and easy module placement enables wider application and flexible stock control.
- Detector is made of high endurance, solid and colorfast Fire-proof plastic.
- Non-loosening screws on base terminal for easy installation.
- Detector has passed strict EMC test, which greatly eliminates false alarms caused by interference from nearby sources.
- Dual LEDs for 360-degree visibility. Bi-color LED, Stand-by Status: Green; Alarm Status: Red.

Specifications

Model	Q06-2	Q06-3	Q06-4
Alarm Contact	N/A	N/A	0.8A @30V DC 0.4A @125V AC
Voltage Range	12 ~ 30V DC		
Alarm Current @24V DC 470Ω	40mA	40mA	45mA
Standby Current @24V DC 470Ω	under 95μA		
Thermal Setting	58°C		
Ambient Temperature	-10°C ~ +55°C		
Material	Fire-proof plastic		
Dimensions	102mm(Dia.) x 46mm(H)		
Weight	115g	115g	130g
Color	White		

Effective alert area

Construction/Height	Under 4M	4M ~ 8M
Fire-proof Building	90 M ²	45 M ²
Ordinary Building	50 M ²	30 M ²

Order information

Q06-2	2-wire
Q06-3	3-wire with remote indicator output
Q06-4	4-wire with relay output

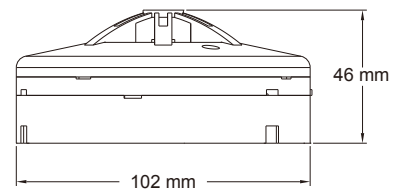

506c/04/05/06

0832

8011

Photoelectric Smoke Detector



Characteristics

- The standard detector is 2-wire or 3-wire. For 4-wire type just add one relay output module on 3-wire base. Simple and easy module placement enables wider application and flexible stock control.
- Detector is made of high endurance, solid and colorfast Fire-proof plastic.
- Non-loosening screws on base terminal for easy installation.
- Detector has passed strict EMC test, which greatly eliminates false alarms caused by interference from nearby sources.
- Dual LEDs for 360-degree visibility. Bi-color LED, Stand-by Status: Green; Alarm Status: Red.

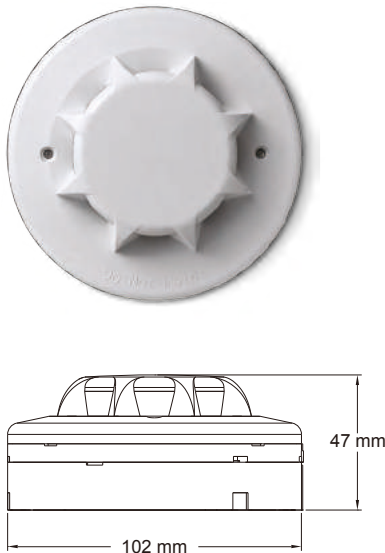

Specifications

Model	8011-2	8011-3	8011-4
Alarm Contact	N/A	N/A	0.8A @30V DC 0.4A @125V AC
Voltage Range	12 ~ 30V DC		
Alarm Current @24V DC 470Ω	40mA	40mA	45mA
Standby Current @24V DC 470Ω	25 ~ 75μA		
Sensitivity Setting	Comply to EN54		
Ambient Temperature	-10°C ~ +55°C		
Material	Fire-proof plastic		
Dimensions	102mm(Dia.) x 47mm(H)		
Weight	130g	130g	145g
Color	White		

Effective alert area

Building Height	Area Covered
Under 4M	150 M ²
4 ~ 20M	75 M ²

Order information

8011-2	2-wire
8011-3	3-wire with remote indicator output
8011-4	4-wire with relay output
8011-2M	2-wire + magnetic test feature
8011-3M	3-wire with remote indicator output + magnetic test feature
8011-4M	4-wire with relay output + magnetic test feature



AH-0715

Combination Smoke and Heat Detector

Characteristics

- Magnetic test feature makes maintenance easy and simple.
- Twin-color LED display enables viewer to easily identify the current status of detector.
- The standard detector is 2-wire or 3-wire. For 4-wire type just add one relay output module on 3-wire base. Simple and easy module placement enables wider application and flexible stock control.
- Detector is made of high endurance, solid and colorfast Fire-proof plastic.
- Non-loosening screws on base terminal for easy installation.
- Detector has passed strict EMC test, which greatly eliminates false alarms caused by interference from nearby sources.

Specifications

Model	AH-0715-2	AH-0715-3	AH-0715-4
Alarm Contact	N/A	N/A	0.8A @30V DC 0.4A @125V AC
Voltage Range	12 ~ 30V DC		
Alarm Current @24V DC 470Ω	40mA	40mA	45mA
Standby Current @24V DC 470Ω	35 ~ 85μA		
Sensitivity Setting	Comply to EN54		
Thermal Setting	58°C		
Ambient Temperature	-10°C ~ +55°C		
Material	Fire-proof plastic		
Dimensions	102mm(Dia.) x 54mm(H)		
Weight	130g	130g	145g
Color	White		

Effective alert area

Building Height	Area Covered
Under 4M	150 M ²
4 ~ 20M	75 M ²

Order information

AH-0715-2	2-wire
AH-0715-3	3-wire with remote indicator output
AH-0715-4	4-wire with relay output
AH-0715-2M	2-wire + magnetic test feature
AH-0715-3M	3-wire with remote indicator output + magnetic test feature
AH-0715-4M	4-wire with relay output + magnetic test feature

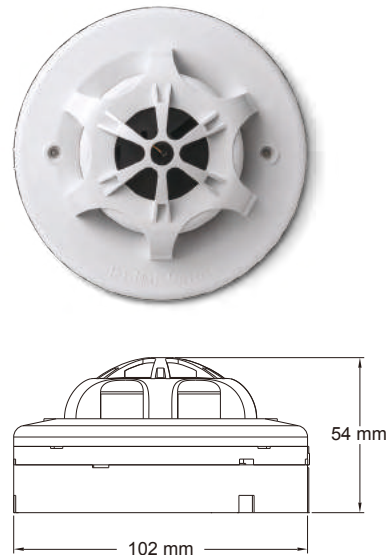

8016

Heat Detector



Characteristics

- Magnetic test feature makes maintenance easy and simple.
- The standard detector is 2-wire or 3-wire. For 4-wire type just add one relay output module on 3-wire base. Simple and easy module placement enables wider application and flexible stock control.
- Detector is made of high endurance, solid and colorfast Fire-proof plastic.
- Non-loosening screws on base terminal for easy installation.
- Detector has passed strict EMC test, which greatly eliminates false alarms caused by interference from nearby sources.
- Dual LEDs for 360-degree visibility.

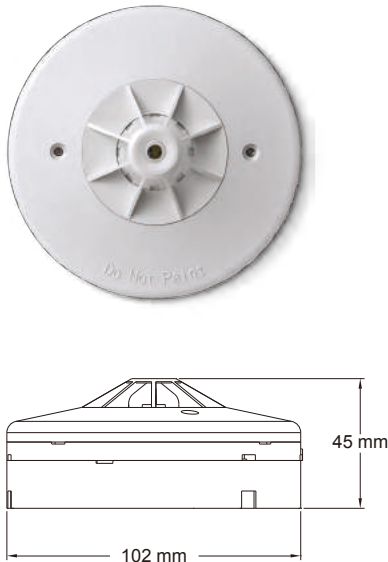

Specifications

Model	8016-2	8016-3	8016-4
Alarm Contact	N/A	N/A	0.8A @30V DC 0.4A @125V AC
Voltage Range	12 ~ 30V DC		
Alarm Current @24V DC 470Ω	40mA	40mA	45mA
Standby Current @24V DC 470Ω	20 ~ 90μA		
Thermal Setting	58°C		
Ambient Temperature	-10°C ~ +55°C		
Material	Fire-proof plastic		
Dimensions	102mm(Dia.) x 45mm(H)		
Weight	115g	115g	130g
Color	White		

Effective alert area

Construction/Height	Under 4M	4 ~ 8M
Fire-proof Building	90 M ²	45 M ²
Ordinary Building	50 M ²	30 M ²

Order information

8016-2	2-wire
8016-3	3-wire with remote indicator output
8016-4	4-wire with relay output
8016-2M	2-wire + magnetic test feature
8016-3M	3-wire with remote indicator output + magnetic test feature
8016-4M	4-wire with relay output + magnetic test feature



AH-0933

Mechanical Rate of Rise Heat Detector

Characteristics

- Detector is made of high endurance, solid and colorfast Fire-proof plastic.
- Non-loosening screws on base terminal for easy installation.
- The unit is completely sealed; its function is not affected by humidity, dust or insects.
- This detector has passed strict quality control and repetitive testing, hence its quality is stable and highly reliable.

Specifications

Model	AH-0933	
Type	2-wire	
Voltage Range	12 ~ 30V DC	
Alarm Current @24V DC 470Ω	40mA	
Alarm Temperature	Comply to EN54	
Ambient Temperature	0°C ~ +55°C	
Material	Fire-proof plastic	
Dimensions	102mm(Dia.) x 46mm(H)	
Weight	About 130g	
Color	White	

Effective alert area

Construction/Height	Under 4M	4M ~ 8M
Fire-proof Building	90 M ²	45 M ²
Ordinary Building	50 M ²	30 M ²

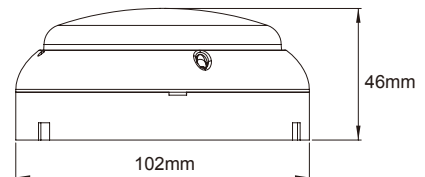

IR-0714/IR-0814



IR Flame Detector

IR-0814



IR-0714

Characteristics

- Built-in high performance Microprocessor that able to analysis flame signal more accuracy.
- IR sensor has better detection range than UV sensor.
- High immunity to sunlight or other noisy source.

Applications

- Premises with higher ceilings: theater, gym, storage, gallery or warehouse, etc.
- Places where fires happen easily: places storing with combustible goods, gas stations, factory working places, machine rooms, etc.
- Ventilate places: open markets, station platforms, hotel lobbies, department stores, etc. (places that smoke and heat can not gather during early period of fire)
- Others: tunnels, computer rooms, etc.

Specifications:

Model	IR-0714-2	IR-0714-3	IR-0714-4	IR-0814-2	IR-0814-3	IR-0814-4
Type	2-wire	3-wire	4-wire	2-wire	3-wire	4-wire
Alarm Contact	N/A	N/A	0.8A @ 30V DC 0.4A @125V AC	N/A	N/A	0.8A @ 30V DC 0.4A @125V AC
Sensor Type	Single IR			Dual IR		
Wavelength	4.35μm			4.35μm 3.40μm		
Standby Current @24V DC 470Ω	under 200μA			under 250μA		
Voltage Range	12V~30V DC					
Alarm Current @24V DC 470Ω	35mA					
Ambient Temperature	-10°C+55°C					
Material	Fire-proof plastic					
Dimensions	102 mm (Dia.) × 38 mm (H)					
Weight	130g	130g	145g	130g	130g	145g
Color	White					

Installation Instructions

1. Do not install detector that has fire source nearby.
2. Detection range and angle please refer to diagram as below.

Detection range and angle:

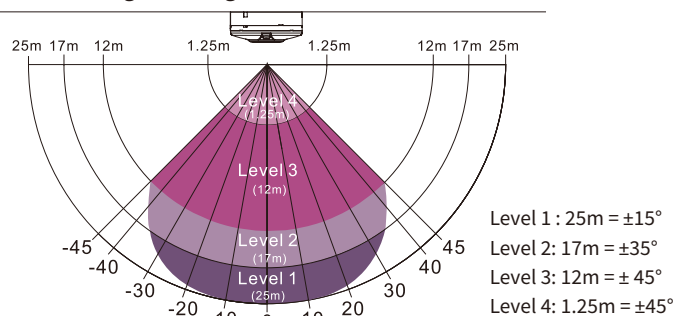

AHMB-071

Mounting Base



AHMB-071



Implanted-Type

Design Characteristics

- The standard detector is 2-wire or 3-wire. For 4-wire type just add one relay output module on 3-wire base. Simple and easy module placement enables wider application and flexible stock control.
- Major advantage of using the compatible mounting base is to avoid wasting time selecting proper detectors for various purposes and be able to install the base quickly and continuously. Afterwards, just plug-in proper detector head to complete the project.
- Applies to model nos. Q01, Q05, Q06, AH-0621, 8011, AH-0715, 8016 and AH-0933.

Order information

Model	Feature, Application
AHMB-071-2	2-wire Apply to fire alarm control panel
AHMB-071-3	3-wire Auxiliary for remote indicating lamp
AHMB-071-4	4-wire 12 ~ 24VDC, optional one set of relay output. Apply to security system...etc.
06MB	Implanted-Type Applies to 2-wire, 3-wire, 4-wire.



2-Wire Type (Regular)

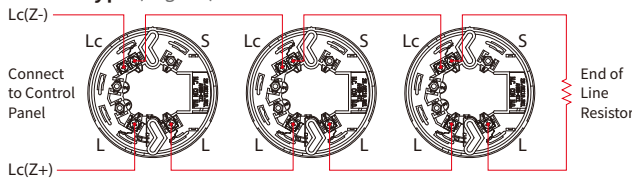

3-Wire Type (Signal Transfer)

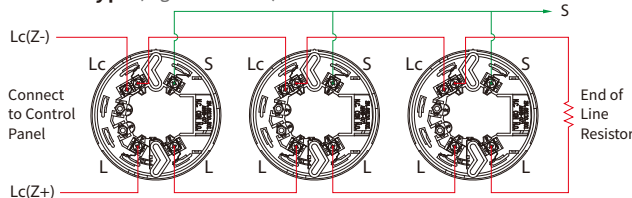

4-Wire Type (Relay Output) Contact Ratings 0.8A @30V DC 0.4A@125V AC

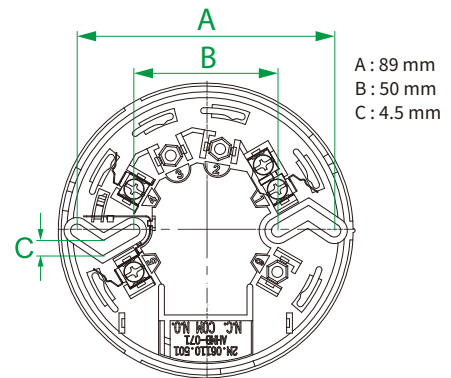
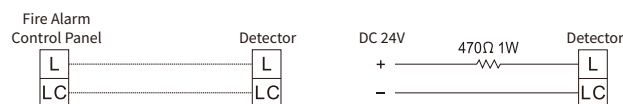
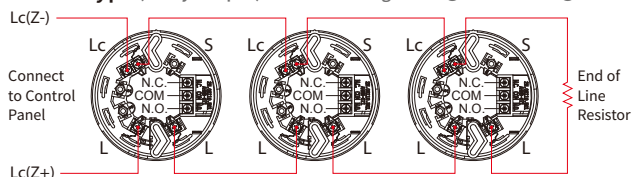

AH-031 Series

- AH-0311 Multi-Purpose Smoke Detector
- AH-0315 Multi-Purpose Smoke and Heat Detector
- AH-0316 Multi-Purpose Combination Heat Detector

Multi-purpose Resettable Type

This unit has designed for relay output feature with optional individual power source and it has been used widely in the current market. This resettable detector is not only use as a fire alarm system but will also supervise input power via an optional relay output for power breakdown or wire break. Fault relay contact will open when power breakdown occur and fire alarm signal will transmitted to connected system or computer terminal when detector is activated. When the alarm signal is absent the detector will automatically return to standby status. Optional built-in buzzer can sound a warning at the first sign of fire. This detector is currently used quite often in security systems and is also promoted for use in communications, banking, shipping or the art business.

Characteristics

- Special chamber design has greatly decreased dust levels and improved detection accuracy.
- Dual LEDs for 360-degree visibility.
- Advanced technology enables this detector to increase its precision in fire detection, improve signals to avoid noise interference and thus reduce unwanted false alarm.
- Low current consumption that allows more detectors to be used with each control panel.
- Dual contacts on the base which enhance the connecting stability between sensor and base.
- All bases are fitted with a shorting spring to permit maintenance without disconnecting when removing the detector head.



AH-0311



AH-0315



AH-0316

AH-031 Series



AH-0311

Multi-Purpose Smoke Detector

Specifications

Model	AH-0311-2	AH-0311-3	AH-0311-4
Voltage Range	12 ~ 30V DC		
Standby Current @24V DC 470Ω	under 40μA		
Alarm Current @24V DC 470Ω	40mA	30mA	40mA
Sensitivity Setting	Comply to EN54		
Ambient Temperature	-10°C ~ +55°C		
Material	Fire-proof plastic		
Dimensions	102mm(Dia.) x 49mm(H)		
Weight	155g	157g	165g
Color	White		

Order information

AH-0311-2	2-wire
AH-0311-3	3-wire with remote indicator output
AH-0311-4	4-wire with relay output

Specifications (Resettable)

Model	AH-0311-S	AH-0311-BS	AH-0311-BPS
Alarm Current	15mA	50mA	80mA
Standby Current	115μA	115μA	15mA
Voltage Range	12V DC	12V DC	12V DC
Weight	168g	170g	170g

Order information (Resettable)

AH-0311-S	+ Relay Output
AH-0311-BS	+ Buzzer + Relay Output
AH-0311-BPS	+ Buzzer + Power off & Wire Disconnection Warning + Relay Output

Effective alert area

Building Height	Area Covered
Under 4M	150 M ²
4 ~ 20M	75 M ²

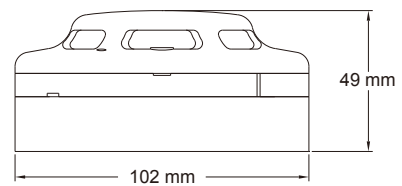

AH-0315

Multi-Purpose Smoke and Heat Detector

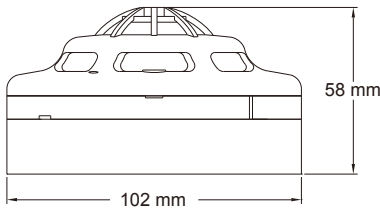

Specifications

Model	AH-0315-2	AH-0315-3	AH-0315-4
Voltage Range	12 ~ 30V DC		
Standby Current @24V DC 470Ω	under 55μA		
Alarm Current @24V DC 470Ω	40mA	30mA	40mA
Sensitivity Setting	Comply to EN54		
Thermal Setting	58°C		
Response Grade	Comply to EN54, Grade 1		
Ambient Temperature	-10°C ~ +55°C		
Material	Fire-proof plastic		
Dimensions	102mm(Dia.) x 58mm(H)		
Weight	155g	157g	165g
Color	White		

Order information

AH-0315-2	2-wire
AH-0315-3	3-wire with remote indicator output
AH-0315-4	4-wire with relay output

Specifications (Resettable)

Model	AH-0315-S	AH-0315-BS	AH-0315-BPS
Alarm Current	25mA	65mA	80mA
Standby Current	125μA	125μA	15mA
Voltage Range	12V DC	12V DC	12V DC
Weight	164g	166g	171g

Order informations (Resettable)

AH-0315-S	+ Relay Output
AH-0315-BS	+ Buzzer + Relay Output
AH-0315-BPS	+ Buzzer + Power off & Wire Disconnection Warning + Relay Output

Effective alert area

Building Height	Area Covered
Under 4M	150 M ²
4 ~ 20M	75 M ²





AH-0316

Multi-Purpose Combination Heat Detector

Specifications

Model	AH-0316-2	AH-0316-3	AH-0316-4
Voltage Range	12 ~ 30V DC		
Standby Current @24V DC 470Ω	under 45μA		
Alarm Current @24V DC 470Ω	30mA	35mA	40mA
Thermal Setting	58°C		
Response Grade	Comply to EN54, Grade 1		
Ambient Temperature	-10°C ~ +55°C		
Material	Fire-proof plastic		
Dimensions	102mm(Dia.) x 58mm(H)		
Weight	145g	147g	160g
Color	White		

Order information

AH-0316-2	2-wire
AH-0316-3	3-wire with remote indicator output
AH-0316-4	4-wire with relay output

Specifications (Resettable)

Model	AH-0316-S
Alarm Current	35mA
Standby Current	30μA
Voltage Range	12V DC
Weight	157g

Order information (Resettable)

AH-0316-S	+ Relay Output
-----------	----------------

Effective alert area

Construction/Height	Under 4M	4M ~ 8M
Fire-proof Building	90 M ²	45 M ²
Ordinary Building	50 M ²	30 M ²

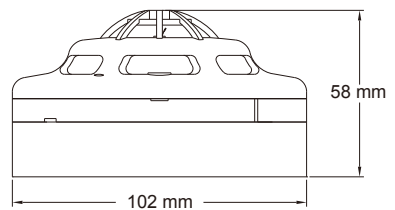

AHMB-031

Multi-Purpose Mounting Base



Design Characteristics

The detector base is designed for use on all AH-031 series fire detection devices. It has a built-in shorting spring for use when the detector head is removed, which will prevent an open circuit fault condition at control panel during maintenance.

- Applies to model nos. AH-0311, AH-0315, and AH-0316.



GB-031-S
Height: 27mm

GB-031-T
Height: 34mm

Diagram

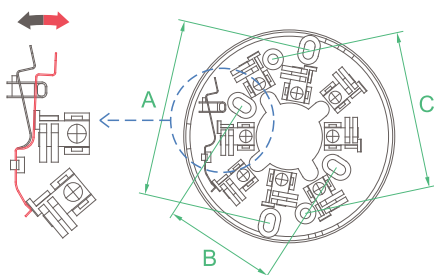

Black : Normal
Red : Close Circuit

A : 81~89mm
B : 50~59mm
C : 75.5mm



2, 3-Wire Type 3-Wire Type (see green line)

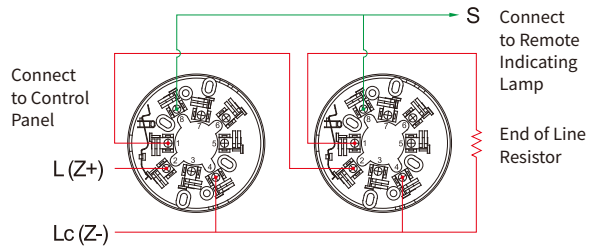

4-Wire Type (Relay Output) Contact Ratings 0.8A @30V DC 0.4A @125V AC

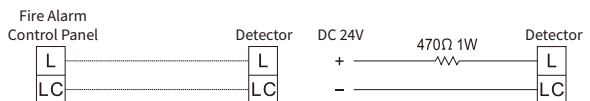
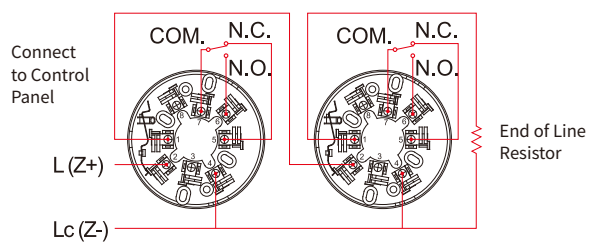

Resettable

Alarm Output :

Normal Status
5 & 7 short circuit
6 & 7 open circuit
Alarm Status
6 & 7 short circuit
5 & 7 open circuit

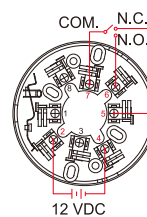

Disconnection or Power-off Warning :

Normal Status
7 & 8 short circuit
Fault Status
7 & 8 open circuit

Contact Ratings
0.8A @ 30V DC
0.4A @ 125V AC

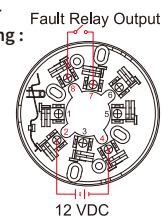



AH-0621

Photoelectric Smoke Detector

Characteristics

- Contacts material is highly acid-resistant and rust-resistant.
- Twin-color LED display enables viewer to easily identify the current status of detector.
- Detector is made of high endurance, solid and colorfast Fire-proof plastic.
- The standard detector is 2-wire or 3-wire. For 4-wire type just add one relay output module on 3-wire base. Simple and easy module placement enables wider application and flexible stock control.
- Non-loosening screws on base terminal for easy installation.
- Detector has passed strict EMC test, which greatly eliminates false alarms caused by interference from nearby sources.

Specifications

Model	AH-0621-2	AH-0621-3	AH-0621-4
Alarm Contact	N/A	N/A	0.8A @30V DC 0.4A @125V AC
Voltage Range	12 ~ 30V DC		
Alarm Current @24V DC 470Ω	50mA	59mA	45mA
Standby Current @24V DC 470Ω	140μA		25~75μA
Sensitivity Setting	Comply to UL 268		
Ambient Temperature	0°C ~ +37.8°C		
Material	Fire-proof plastic		
Dimensions	102mm(Dia.) x 48mm(H)		
Weight	130g	130g	145g
Color	White		

Effective alert area

Building Height	Area Covered
Under 4M	150 M ²
4 ~ 20M	75 M ²

Order information

AH-0621-2	2-wire
AH-0621-3	3-wire with remote indicator output
AH-0621-4	4-wire with relay output

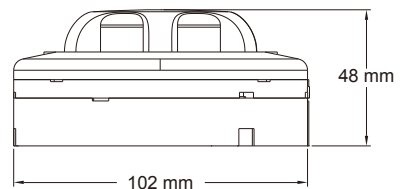

AH-0625

Combination Smoke and Heat Detector



Characteristics

- Each visible warning has 3 modes to easily identify current status.
- Microprocessor control makes smoke and heat detection more accuracy.
- Detector is made of high endurance, solid and colorfast Fire-proof plastic.
- Non-loosening screws on base terminal for easy installation.
- Detector has passed strict EMC test, which greatly eliminates false alarms caused by interference from nearby sources.
- Dual LEDs for 360-degree visibility.

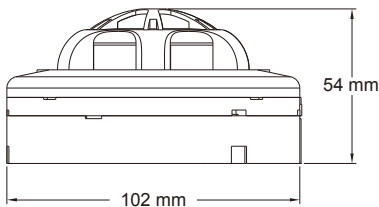

Specifications

Mode	AH-0625-2	AH-0625-3	AH-0625-4
Alarm Contact	N/A	N/A	0.8A @30V DC 0.4A @125V AC
Voltage Range	12 ~ 30V DC		
Alarm Current @24V DC 470Ω	40mA	40mA	45mA
Standby Current @24V DC 470Ω	30 ~ 80μA		
Sensitivity Setting	Comply to UL 268		
Thermal Setting	57°C		
Indicator	Standby: flash every 4 seconds Pre-alarm: flash every 2 seconds Abnormal: flash once every second		
Ambient Temperature	0°C ~ +37.8°C		
Material	Fire-proof plastic		
Dimensions	102mm(Dia.) x 54mm(H)		
Weight	130g	130g	145g
Color	White		

Effective alert area

Building Height	Area Covered
Under 4M	150 M ²
4 ~ 20M	75 M ²

Order information

AH-0625-2	2-wire
AH-0625-3	3-wire with remote indicator output
AH-0625-4	4-wire with relay output



AH-0626

Heat Detector

Characteristics

- Microprocessor control makes heat detection more accuracy.
- Detector is made of high endurance, solid and colorfast Fire-proof plastic.
- Non-loosening screws on base terminal for easy installation.
- Features an accumulated water discharger to eliminate leakage of water from the water pipes or ceiling which may leak into the detector and cause a false alarm.
- Dual LEDs for 360-degree visibility.

Specifications

Model	AH-0626-2	AH-0626-3	AH-0626-4
Alarm Contact	N/A	N/A	0.8A @30V DC 0.4A @125V AC
Voltage Range	12 ~ 30V DC		
Alarm Current @24V DC 470Ω	40mA	40mA	45mA
Standby Current @24V DC 470Ω	70μA		
Thermal Setting	60°C		
Ambient Temperature	0°C ~ +37.8°C		
Material	Fire-proof plastic		
Dimensions	102mm(Dia.) x 46mm(H)		
Weight	120g	120g	130g
Color	White		

Effective alert area

Construction/Height	Under 4M	4M ~ 8M
Fire-proof Building	90 M ²	45 M ²
Ordinary Building	50 M ²	30 M ²

Order information

AH-0626-2	2-wire
AH-0626-3	3-wire with remote indicator output
AH-0626-4	4-wire with relay output

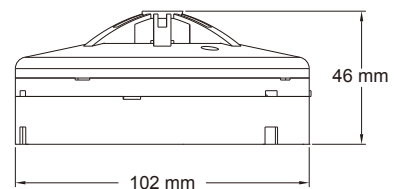

AH-9315

Combination Smoke and Heat Detector



Characteristics

- Multi-purpose Design: when there is smoke or heat during pre-fire period, field situation will vary due to different environments. This combination design is to ensure that the pre-fire confirmation will not be affected by varying environments.
- Smoke gate has a special design to obscure the strong light effectively and allow smoke to come in easily. Water vapor will not gather on the insect guard screen to cause a false alarm.
- Features an accumulated water discharger to eliminate leakage of water from the water pipes or ceiling which may leak into the detector and cause a false alarm.
- This detector has passed strict quality control and repetitive testing, hence its quality is stable and highly reliable.

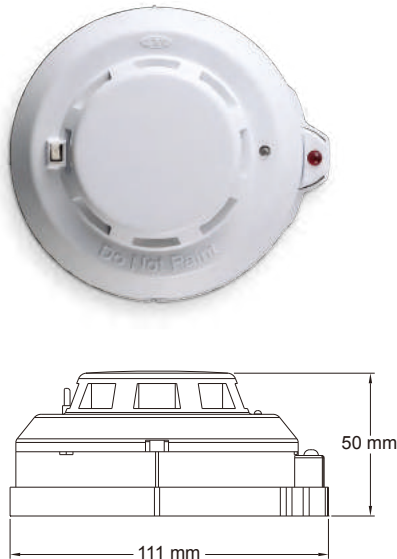

Specifications

Model	AH-9315		
Type	2-wire	3-wire	4-wire
Alarm Contact	N/A	N/A	0.8A @30V DC 0.4A @125V AC
Voltage Range	12 ~ 30V DC		
Alarm Current @24V DC 470Ω	40mA	40mA	35mA
Standby Current @24V DC 470Ω	20 ~ 85μA (Loop response under 75μA)		
Sensitivity Setting	Comply to EN54		
Thermal Setting	55°C		
Ambient Temperature	-10°C ~ +55°C		
Material	Fire-proof plastic		
Dimensions	111mm(Dia.) x 50mm(H)		
Weight	About 170g		
Color	White		

Effective alert area

Building Height	Area Covered
Under 4M	150 M ²
4 ~ 20M	75 M ²





AHR-871

Mechanical Rate of Rise Heat Detector

Characteristics

- Heat-sensing diaphragm can operate for unlimited number of times and is not affected by room temperature. The conducting parts use gold coating to avoid oxidation.
- Uses alloy air equalizer to avoid humidity and stabilize the ventilation function. Alloy itself has many micro-holes that can expel non-fire heat to avoid false alarms.
- The unit is completely sealed; its function is not affected by humidity, dust or insects.
- This detector has passed strict quality control through automatic repetitive testing and been calibrated automatically under stable temperature and humidity conditions. Thus, quality and reliability are consistent from the first detector produced to millionth.

Specifications

Model	AHR-871		
Type	2-wire	3-wire	4-wire
Alarm Contact	N/A	N/A	0.8A @30V DC 0.4A @125V AC
Voltage Range	12 ~ 30V DC		
Alarm Current @24V DC 470Ω	40mA	40mA	35mA
Alarm Temperature	Comply to EN54		
Ambient Temperature	0°C ~ +55°C		
Material	Fire-proof plastic		
Dimensions	111mm(Dia.) x 45mm(H)		
Weight	About 130g		
Color	White		

Effective alert area

Construction/Height	Under 4M	4M ~ 8M
Fire-proof Building	90 M ²	45 M ²
Ordinary Building	50 M ²	30 M ²

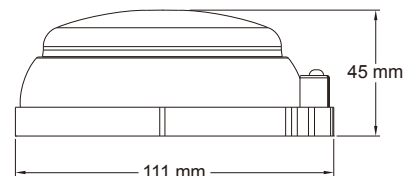

AH-9920

Mechanical Fixed Temperature Heat Detector



Characteristics

- This detector operates on the temperature differential sensing principle, with a UL approved sensor making mechanical contact. It is made of high quality material, providing excellent contact despite any environmental interference.
- This detector is suitable for locations with high temperatures differentials, such as places (kitchen, restaurant and boiler house) where there is constant use of heat.
- This detector has passed strict quality control and repetitive testing; hence its quality is durable and highly reliable.
- Through its professional design, the heat collector can accelerate its response rate after being heated, and has a protective device to avoid accidental response caused by distortion, bumping and dropping in order to increase the reliable product.
- The unit is completely sealed; its function is not affected by humidity, dust or insects.

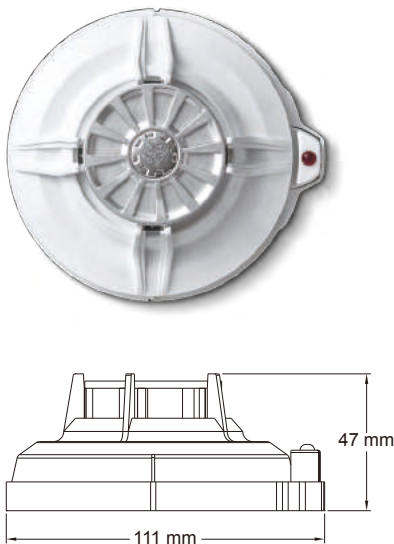

Specifications

Model	AH-9920		
Type	2-wire	3-wire	4-wire
Alarm Contact	N/A	N/A	0.8A @30V DC 0.4A @125V AC
Thermal Setting	70°C or other selections		
Voltage Range	12 ~ 30V DC		
Alarm Current @24V DC 470Ω	40mA	40mA	35mA
Alarm Temperature	Comply to EN54		
Ambient Temperature	-10°C ~ +55°C		
Material	Fire-proof plastic		
Dimensions	111mm(Dia.) x 47mm(H)		
Weight	About 100g		
Color	White		

Effective alert area

Construction/Height	Under 4M	4M ~ 8M
Fire-proof Building	60 M ²	30 M ²
Ordinary Building	30 M ²	15 M ²





AH-0014

Flame Detector

Description

The detector has wide-angle sensitivity that can reliably and quickly detect weak ultraviolet radiations emitted by flame. It will not react to room illuminations, infrared or other light sources unrelated to real fire.

Applications

- Premises with higher ceilings: theater, gym, storage, gallery or warehouse, etc.
- Places where fires happen easily: places storing with combustible goods, gas stations, factory working places, machine rooms, etc.
- Ventilate places: open markets, station platforms, hotel lobbies, department stores, etc. (places that smoke and heat can not gather during early period of fire)
- Others: tunnels, computer rooms, etc.

Installation Instructions

1. Install at obstruction-free places.
2. Avoid installing near mercury lamps, halogen lamps and sterilization lamps.
3. Avoid installing within sensitive range of welding sparks and radiation.

Specifications

Model	AH-0014		
Type	2-wire	3-wire	4-wire
Alarm Contact	N/A	N/A	0.8A @30V DC 0.4A @125V AC
Voltage Range	12 ~ 30V DC		
Alarm Current @24V DC 470Ω	40mA	40mA	35mA
Standby Current @24V DC 470Ω	under 100μA		
Sensor Type	Ultraviolet		
Sensitivity Angle	120°		
Sensitivity Range	It can detect flame of 15mm at distance of 3m		
Ambient Temperature	-10°C ~ +55°C		
Material	Fire-proof plastic		
Dimensions	111mm(Dia.) x 47mm(H)		
Weight	About 170g		
Color	White		



Mounting Base

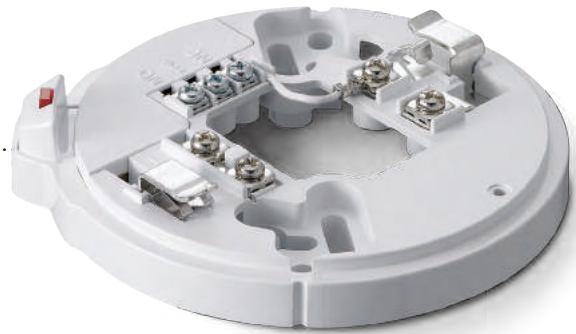

Large 6"

Regular 4"

Design Characteristics

- Major advantage of using the compatible mounting base is to avoid wasting time selecting proper detectors for various purposes and be able to install the base quickly and continuously. Afterwards, just plug-in proper detector head to complete the project.
- Large 6" mounting base is basically designed to match the entire decoration design.
- Applies to model nos. AH-9315, AHR-871, AH-9920, and AH-0014.

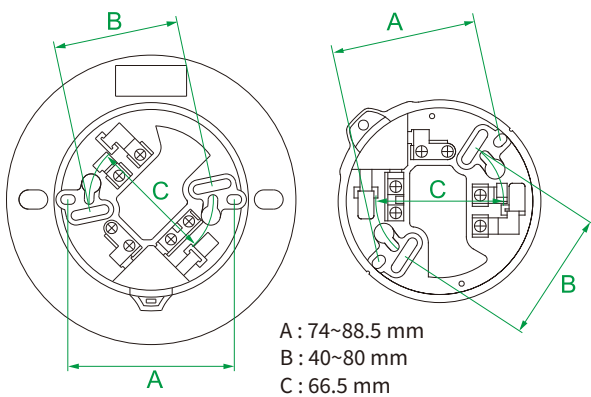

Order information

Regular 4"			
Model	AHMB-L	AHMB-L3	AHMB-L4
Type	2-wire	3-wire	4-wire
Large 6"			
Model	AHMB-62	AHMB-63	AHMB-64
Type	2-wire	3-wire	4-wire

2-Wire Type (Regular)

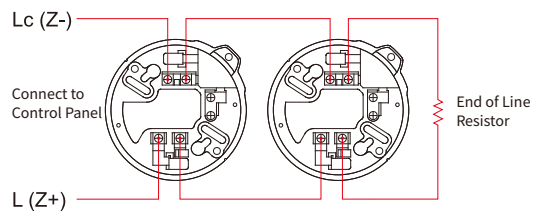

3-Wire Type (Signal Transfer)

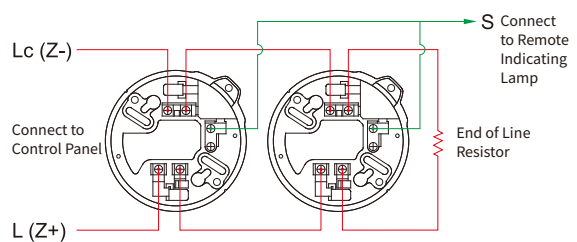

4-Wire Type (Relay Output) Contact Ratings 0.8A @30V DC 0.4A @125V AC

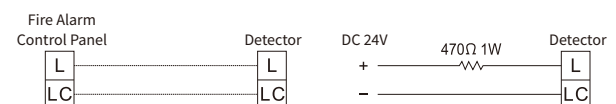
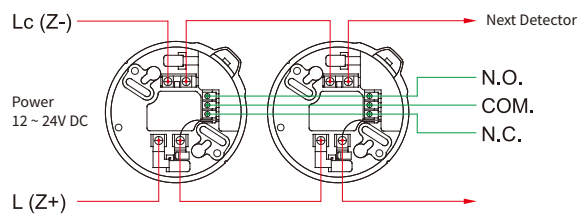



Implanted-Type Mounting Base

Design Characteristics

- This unique mounting base is set into the ceiling and it is designed to match a room's original decoration design and visual effect perfectly. Furthermore, it will make the entire decoration look even better.
- This base has an optional Power-off Warning feature to ensure that the system will operate normally.
- Applies to model nos. AH-9315, AHR-871, AH-9920 and AH-0014.

2-Wire Type (Regular)

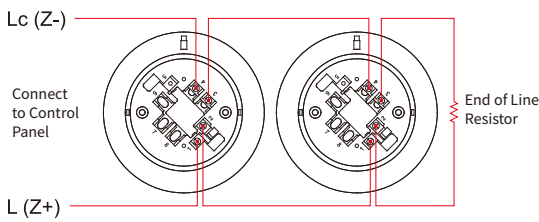

3-Wire Type (Signal Transfer)

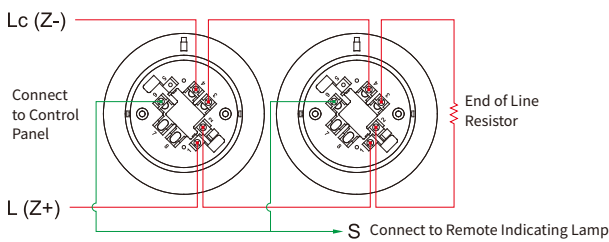

4-Wire Type (Relay Output) Contact Ratings 0.8A @30V DC 0.4A @125V AC

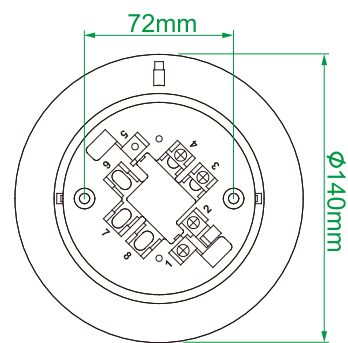
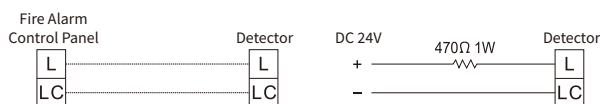
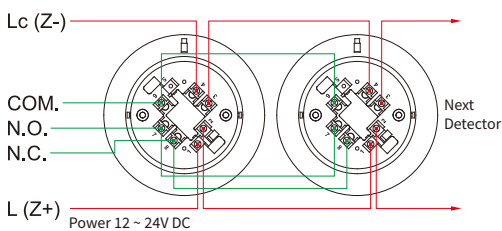

Order information

Model	Features, Application
AHMB-2	2-wire Apply to fire alarm control panel.
AHMB-3	3-wire Auxiliary for remote indicating lamp.
AHMB-4	4-wire 12~24VDC, optional one set of relay output. Apply to security system...etc.

NQ12

Resettable Type Smoke Detector



Characteristics

- Used widely in fire alarm systems or security systems.
- High accuracy IR diode sensor to detect the ambient smoke level more effectively.
- Several power regulators on PCB to stabilize the operation of detectors.
- New design on minified chamber makes so easy for maintenance.

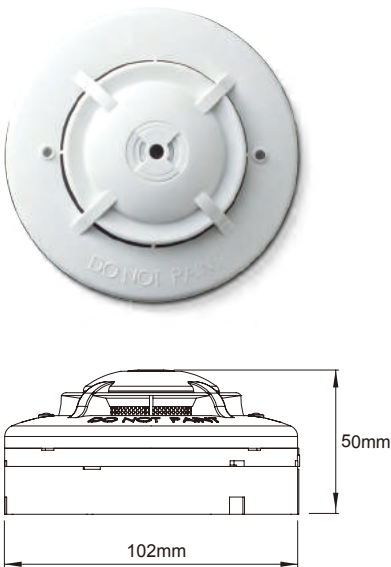

Specifications

Model	NQ12S	NQ12BS	NQ12BPS
Voltage Range	12V DC		
Standby Current	20uA (pulsing current under 450 uA)		15mA
Alarm Current @12V DC	15mA	20mA	30mA
Sensitivity Setting	Comply to UL 268		
Sound	85dB/3M		
Ambient Temperature	-10°C ~ +55°C		
Material	Fire-proof plastic		
Dimensions	102mm(Dia.) x 50mm(H)		
Color	White		
Weight	135g	140g	155g

Order information

NQ12S	+ Relay Output
NQ12BS	+ Buzzer + Relay Output
NQ12BPS	+ Buzzer + Power off & Wire Disconnection Warning + Relay Output

Wiring Diagram

NQ12S / NQ12BS

Relay output :
Contact Ratings
0.8A@30VDC
0.4A@125VAC
(Refer to Security
System Application)

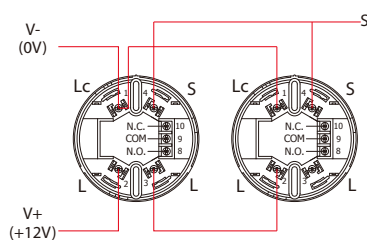

NQ12BPS

Alarm output :
Normal Status : 8 & 9 open circuit
9 & 10 short circuit
Alarm Status : 8 & 9 short circuit
9 & 10 open circuit
Disconnection or Power-off Warning :
Normal Status : 5 & 6 open circuit
6 & 7 short circuit
Fault Status : 5 & 6 short circuit
6 & 7 open circuit

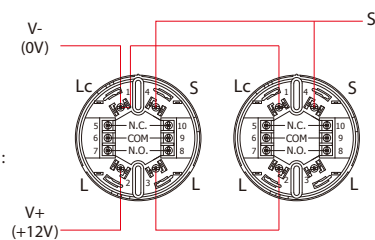



NDKA1 NDKB1

Carbon Monoxide Detector

Description

Carbon Monoxide is as an invisible killer for its colorless, odorless, tasteless and highly toxic gas. It will reduce the oxygen in body's hemoglobin and cause damage to the brain. Our NDKA1 and NDKB1 are equipped with a precise and low power-consumption sensor. With high efficiency microprocessor-based analysis, it can be triggered under different carbon monoxide concentrations.

Characteristics

- Triple-color LED display with high brightness enables viewers to easily identify the status of detector.
- Green LED to confirm the unit is under normal operation.
- Two modes of the Alarm LED in visible and audible warning to easily identify the status.
- Three modes of the Fault LED in visible and audible warning to easily identify the causes.
- Test button for alarm simulation.
- A set of relay output: COM. N.O. N.C. (NDKB1)

Applications

- **Home:** The heating installation such as gas water heater or stove is easy to combust incompletely and then produces CO.
- **Parking lots and garage:** the scooter/cars or engine machine exhausts fumes with high concentration of CO in an enclosed space.
- **Fire:** Smolder is a kind of incomplete combustion. It often occurs before and after the fire as a disaster and produce a large amount of CO.

Specifications

Model	NDKA1	NDKB1
Type	Standalone	System
Power Source	3V DC	12-24V DC
Standby Current	24uA	800uA
Alarm Current	under 65mA	under 40mA
Sensitivity	50 ppm: 60~90 min. 100 ppm: 10~40 min. 300 ppm: 0~3 min.	
Alarm Sound	85dB/3M and above	
Ambient Temperature	-10°C ~ +50°C	
Material	Fire-proof plastic	
Color	White	
Dimensions	102 mm(Dia.) x 45mm(H)	
Weight	About 150g	

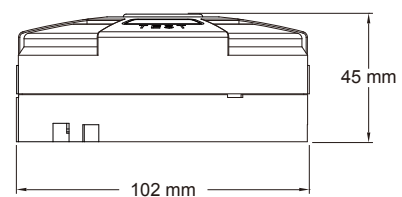

AH-0822

Gas Detector



Characteristics

- The AH-0822 features advanced technology, high accurate detection, low power-consumption and fast reaction time. It can detect natural gas and propane gas. Built-in buzzer and LED indicator alert by sounding and flashing.
- Sounding and flashing in alarm status; the green LED is lit during monitoring and the red LED flashes in alarm status.
- Dual power input: 12VDC and 24VDC operation in the same unit. No adjustment is required.
- Optional 110VAC or 220VAC adaptor is available.
- 1 set of relay output: COM. NO. NC. for CE version.

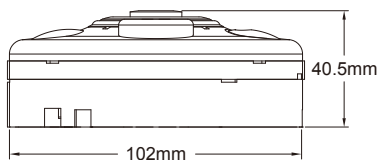

Specifications

Model	AH-0822			
Approval	UL		CE	
Power Source	24V DC	12V DC	24V DC	12V DC
Standby Current	25~30mA	40~45mA	35~40mA	65~70mA
Alarm Current	40~70mA	50~75mA	75~90mA	90~105mA
Warm-up Period	5~8 minutes		about 35 seconds	
Sensitivity	0.021 ~ 0.300% (Propane) 0.050 ~ 0.714% (Methane)		0.050 ~ 0.300%	
Alarm Sound	85dB/3M and above		90dB/M and above	
Detection Type	Natural Gas & Propane Gas			
Ambient Temperature	-10°C ~ +55°C			
Dimensions	102 mm (Dia.) x 40.5 mm(H)			
Weight	About 130g			





NQ3F

Single Station Heat Detector

Characteristics

- Voice warning in English.
- Low power consumption, powered by 3V long-life lithium batteries for 10 years.
- This detector is suitable for locations with high temperatures differentials, such as places (kitchen, restaurant and boiler house) where there is constant use of heat.
- Simple test method: Press test button to hear the alarm sound and confirm the unit is in normal condition.
- Easy installation: Install directly to proper location without any wiring.
- Optional magnetic testing device makes maintenance easy and simple.

Specifications

Model	NQ3F	
Power	3V lithium battery	
Thermal Setting	70°C	
Sound	90dB / M and above	
Ambient Temperature	0°C ~ +50°C	
Material	Fire-proof plastic	
Dimensions	110mm (H) x 102mm (W) x 49mm (D)	
Weight	About 120g	
Color	White	

Effective alert area

Construction/Height	Under 4M	4M ~ 8M
Fire-proof Building	60 M ²	30 M ²
Ordinary Building	30 M ²	15 M ²

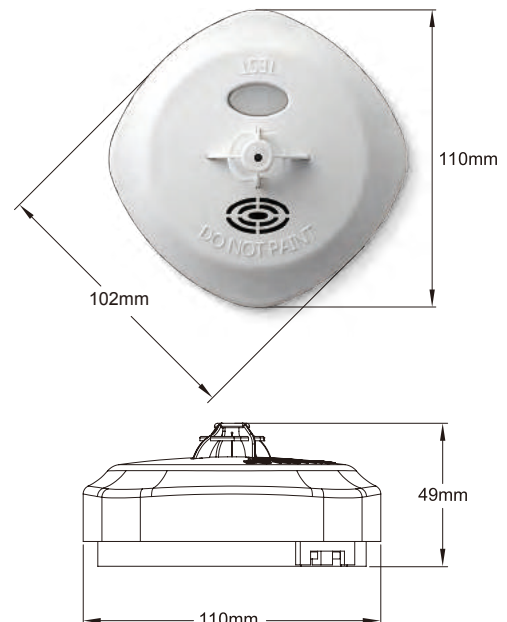

NQ9F

Single Station Heat Detector



Characteristics

- Detector has passed strict quality control and repetitive testing; hence its quality is durable and highly reliable.
- Simple test method: Press test button to hear the alarm sound and confirm the unit is in normal condition.
- Easy installation: Install directly to proper location without any wiring.
- It is equipped with 9VDC battery, and optional 100~240VAC power plug is available.
- Optional relay output : COM. NO. NC.
- Optional series connection wiring can co-activate up to 20 detectors.

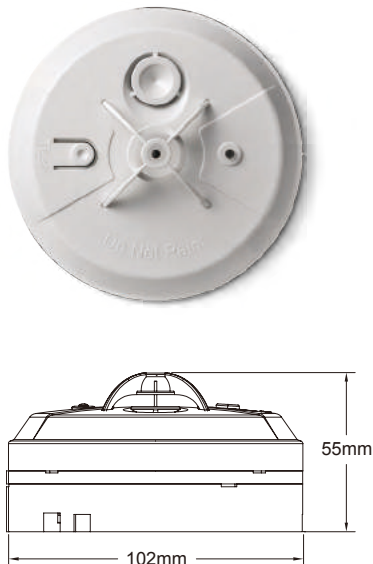

Specifications

Model	NQ9F
Power	9V battery
Thermal Setting	70°C
Indicator	Standby: flash every 40 seconds
	Alarm: flash and beep continuously
	Battery abnormal: beeps and flash intermittently
Sound	90dB / M and above
Ambient Temperature	-10°C ~ +55°C
Material	Fire-proof plastic
Dimensions	102mm(Dia.) x 55mm(H)
Weight	About 150g
Color	White
Optional Function	Type 1 : 9V battery
	Type 2 : includes signal transfer COM. N.O. N.C.
	Type 3 : Type 2 + Type 4
	Type 4 : build-in 110VAC or 220VAC plug

Effective alert area

Construction/Height	Under 4M	4M ~ 8M
Fire-proof Building	60 M ²	30 M ²
Ordinary Building	30 M ²	15 M ²



NQ3S

Single Station Smoke Detector

Characteristics

- Voice warning in English.
- Low power consumption, powered by 3V long-life lithium batteries for 10 years.
- Simple test method: Press test button to hear the alarm sound and confirm the unit is in normal condition.
- Easy installation: Install directly to proper location without any wiring.
- Optional magnetic testing device makes maintenance easy and simple.

Specifications

Model	NQ3S
Power	3V lithium battery
Sensitivity Setting	Comply to EN
Sound	90dB / M and above
Ambient Temperature	0°C ~ +50°C
Material	Fire-proof plastic
Dimensions	110mm (H) x 102mm (W) x 38mm (D)
Weight	About 120g
Color	White

Effective alert area

Building Height	Area Covered
Under 4M	150 M ²
4 ~ 20M	75 M ²

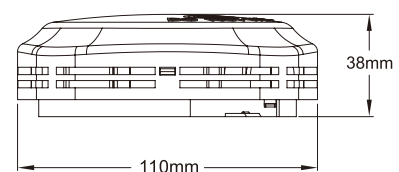

NQ9S

Single Station Smoke Detector



Characteristics

- New design on minified chamber makes so easy for maintenance.
- High luminous LED for light guiding design.
- Detector has passed strict EMC test, which greatly eliminates false alarms caused by interference from nearby sources.
- Simple test method: Press test button to hear the alarm sound and confirm the unit is in normal condition.
- Easy installation: Install directly to proper location without any wiring.
- It is equipped with 9VDC battery, and optional 100~240VAC power plug is available.
- Optional relay output : COM. NO. NC.
- Optional series connection wiring can co-activate up to 20 detectors.

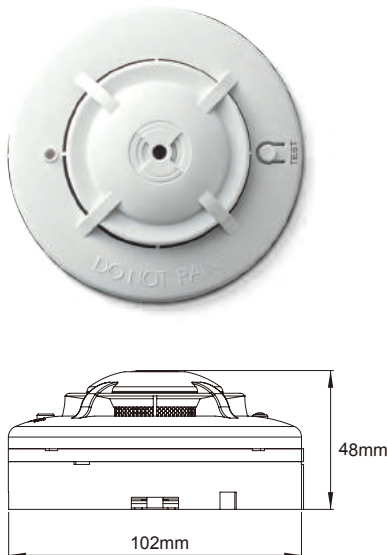

Specifications

Model	NQ9S
Power	9V battery
Sensitivity Setting	Comply to EN14604
Indicator	Standby: flash every 45 seconds
	Alarm: flash and beep continuously
	Battery abnormal: beeps and flash intermittently
Sound	90dB / M and above
Ambient Temperature	0°C ~ +50°C
Material	Fire-proof plastic
Dimensions	102mm(Dia.) x 48mm(H)
Weight	About 165g
Color	White
Optional Function	Type 1 : 9V battery
	Type 2 : includes signal transfer COM. N.O. N.C.
	Type 3 : Type 2 + Type 4
	Type 4 : build-in 110VAC or 220VAC plug

Effective alert area

Building Height	Area Covered
Under 4M	150 M ²
4 ~ 20M	75 M ²

EN14604





QA31

Single Station Smoke Detector

Characteristics

- The QA31 features advanced photoelectric technology for precise detection. When smoke is detected or the manual test button is pressed, the buzzer sounds and LED flash.
- Low-Battery Warning: Unit beeps and LED flash intermittently to indicate battery needs replacing.
- Simple test method: Press test button to hear the alarm sound and confirm the unit is in normal condition.
- Easy installation: Install directly to proper location without any wiring.
- It is equipped with 9VDC battery, and optional 110VAC or 220VAC power plug is available.
- Optional relay output : COM. NO. NC.
- Optional series connection wiring can co-activate up to 15 detectors.

Specifications

Model	QA31
Power	9V battery
Sensitivity Setting	Comply to EN14604
Indicator	Standby: flash every 45 seconds
	Alarm: flash and beep continuously
	Battery abnormal: beeps and flash intermittently
Sound	90dB / M and above
Ambient Temperature	-10°C ~ +55°C
Material	Fire-proof plastic
Dimensions	105mm(Dia.) x 40mm(H)
Weight	About 150g
Color	White
Optional Function	Type 1 : 9V battery
	Type 2 : includes signal transfer COM. N.O. N.C.
	Type 3 : build-in 110VAC or 220VAC plug
	Type 4 : Type 2 + Type 3

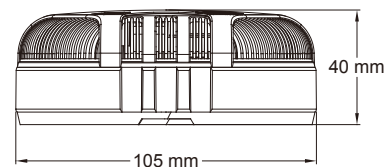

Effective alert area

Building Height	Area Covered
Under 4M	150 M ²
4 ~ 20M	75 M ²



AH-03127

Electronic Sounder and Beacon



AH-03127-BS

AH-03127-S

General

This electronic sounder is designed for use with fire alarm systems, security systems and industrial signaling systems. Combined sounder and beacon provides an audio-visual warning which is suitable for places where high sound output and visual indication is required.

Characteristics

- 32 signal tones selectable by Dip switch.
- High sound output with low current consumption.
- High efficiency lens for maximum light output.
- Volume Control as standard.
- Two sets of IN and OUT terminals, easy for installation.



Specifications

Model	AH-03127-S	AH-03127-BS
Voltage	24V DC	
Current Consumption 24V DC (MAX)	35mA	40mA
Sound Output 24V DC dB (A) at 1 meter	Max. 114	
Volume Control	0 to -20dB adjustment	
Ingress Protection	IP44	
Ambient Temperature	-25°C ~ +80°C	
Material	Fire-proof plastic	
Dimensions	92.5mm(Dia.) x 94mm(H)	92.5mm(Dia.) x 110mm(H)
Weight	254g	278g

Order information

AH-03127-S	Electronic Sounder
AH-03127-BS	Electronic Sounder and Beacon



AH-0817

Resettable Manual Call Point

Features

- Red LED with current limiting resistor.
- Three different resistance selectable (270, 470, 680 ohm).
- Choice of red, yellow, blue or green finish also available for custom-made.
- Clear protection cover is also available (optional).

Specifications

Model	AH-0817
Operating Contact	6A 125/250VAC
Resistance	30MΩ
Ambient Temperature	-25°C ~ +85°C
Dimensions	87.5mm (H) x 87.5mm (W) x 54mm (D)
Weight	About 145g



Wiring

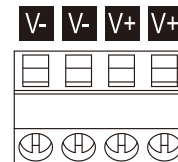

Jumper Selections

- J1** **J2** **J3**
- Clean normally open contact - No LED possible
 - Blocking diode selected - No LED possible
 - Used for future application
 - 270 ohm resistor selected - LED illuminates when the call point is activated
 - 470 ohm resistor selected - LED illuminates when the call point is activated
 - 680 ohm resistor selected - LED illuminates when the call point is activated

AH-0217

Manual Call Point



EN listed

Features

- Available in flush or surface mounted models.
- Plastic film on glass.
- Test key inserted from bottom.
- Suitable for the majority of conventional fire alarm system.
- Clear protection cover is also available (optional).
- Choice of red, yellow, blue or green finish also available for custom-made.



CE listed

Specifications

Model	AH-0217
Operating Contact	6A 125/250VAC
Resistance	30MΩ
Ambient Temperature	-25°C ~ +85°C
Dimensions	88mm(H) x 88mm(W) x 52mm(D)
Weight	About 165g

EN54  



AH-9717



AH-9717 with base

AH-9717

Manual Call Point

Features

- Emergency press alarm, immediately activates fire alarm signal.
- Indicator light above fire alarm push-button confirms the alarm signal transfer.
- There are a phone jack and reset button behind the cover cap.
- Type I is simultaneous dual loop, Type II is simultaneous dual signal transfer (refer to diagram below)
- Optional base is available.

Specifications

Model	AH-9717
Operating Power	24V DC 30mA
Operating Contact	Max. 30V DC 500mA
Sub-function	Phone jack, confirmation LED, reset button.
Material	Fire-proof plastic
Dimensions	140mm(Dia.) x 45mm(H)
Weight	About 160g

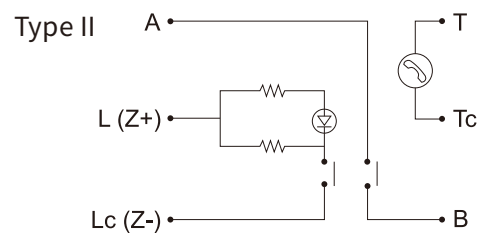
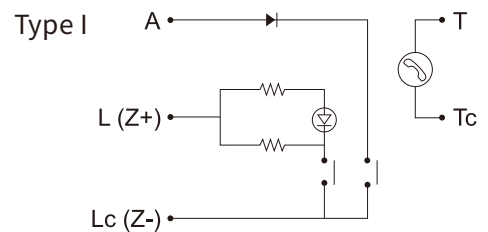

220V AC 0.4A
24V DC 0.8A

NQ618 NQ418

Fire Alarm Bell



NQ618



NQ418

Features

- Bell with plastic base, total insulation from electricity and easy installation.
- Motor energized, low power consumption, long operating life.
- Bell shell is made of steel plate, so it will sound loud and clear.
- 12VDC bells are also available.

Specifications

Model	NQ618	NQ418
Dimensions	ø6" (152mm) x 58mm (H)	ø4" (100mm) x 52mm (H)
Voltage	24V DC	
Current	28mA	
Sound Output	90dB @1M	
Material	Steel Plate	
Base Plate	ABS plastic	
Weight	About 810g	About 375g





AH-0218

AH-0218 AH-9719

Fire Alarm Bell & Indicating Lamp



AH-9719

AH-0218 Fire Alarm Bell 6"

- High efficiency low current consumption on 24VDC motorized bells.
- Terminals will accept 2.5mm cables.
- Simple installation via multi-fixing base plate for all types of location.
- Fitted with two series diodes for fault monitoring.
- Option of customized discs printed with company name and logo.
- *12VDC bells are also available.*

AH-9719 Fire Indicating Lamp

- Uses white bulb (or low current LED) and installed inside the red lamp cover.
- When lit, it is clear visible within 10 meters.

Specifications

Model	AH-0218
Dimensions	ø6" (152mm) x 56mm(H)
Voltage	24V DC
Current	25mA
Sound Output	93dB @1M
Movement	Motor, Pinion and striker
Movement Features	DC Motor, acetal gear wheel, steel striker
Gong	Steel, secured with phillips screw
Base Plate	Molded black polycarbonate
Material	Steel plate
Weight	About 850g

Specifications

Model	AH-9719
Dimensions	90mm(Dia.) x 70mm(H)
Consumption Current	24V DC 60mA / LED 20mA
Bulb	30V/2W bulb or LED
Material	Fire-proof plastic
Weight	About 70g



EN54



AH-03128 AH-07128

Detector Test Device



AH-03128



AH-07128

Characteristics

- For testing heat and smoke detectors.
- Extension pole is very flexible. It has five sections and can expand from 1.44m to 5m.

AH-03128 Detector Testing and Removal Device

- Removal device is designed for AH-031 series detector. (AH-0311, AH-0315 and AH-0316)
- The extension pole on the test vessel allows the user to easily reach the detector.
- The enclosed gas torch its temperature can be adjusted.
- The smoke detector tester can spray about 500 times.

AH-07128 Detector Testing Device

- Use with model nos. 8011, AH-0715, and 8016 with magnetic test feature.

Dimensions of Test Device AH-03128 : mm

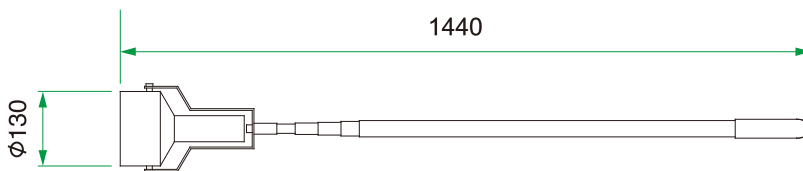

Removal
AH-07152



AH-03151





AH-413

Remote Indicating Lamp

Features

This unit is designed to ensure that alarm signal can be actually transmitted to all locations. Especially for a closed room, any fire inside can be indicate outside.

Characteristics

- Outstanding look from the design of art
- Low current consumption
- High intensity LED for quick identification
- Larger indicating lamp
- Applicable for 12VDC and 24VDC
- Flash light is available for optional feature

Specifications

Model	AH-413
Power Source	12/24V DC
Alarm Current @24V DC	15mA
Standby Current	N/A
Ambient Temperature	-10°C ~ +55°C
Material	Fire-proof plastic
Color	White surface/ Red LED
Dimensions	85mm(H)x85mm(W)x23mm(D)
Weight	About 28g



Wiring Diagram

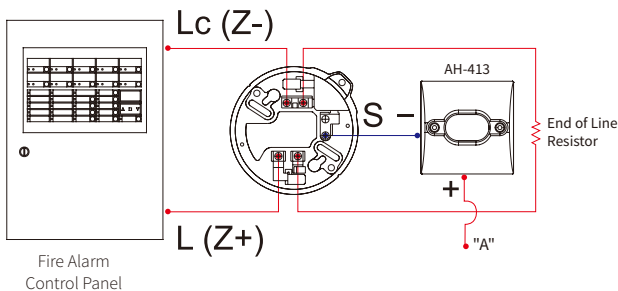

AHMB-071

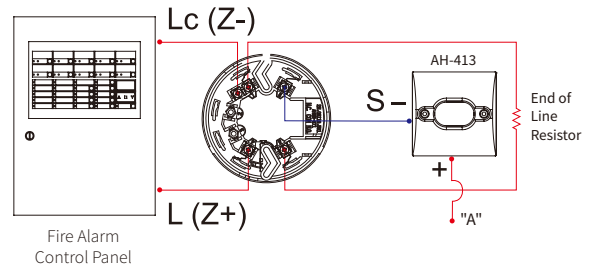

AHMB-031

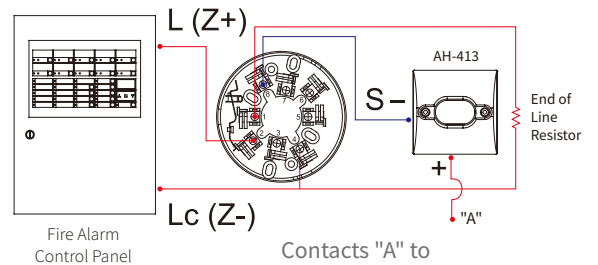

Contacts "A" to
 (1) Fire 24V AUX contacts
 (2) Fire Zone L(Z+)

AH-01313

Remote Indicating Lamp



Features

This unit is designed to ensure that alarm signal can be actually transmitted to all locations. Especially for a closed room, any fire inside can be indicate outside.

Characteristics

- Outstanding look from the design of art
- Low current consumption
- High intensity LED for quick identification

AHMB-071

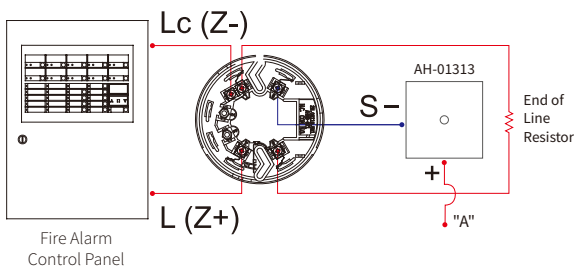

AHMB-031

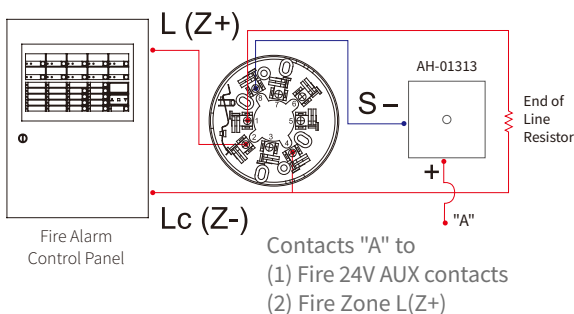

Specifications

Model	AH-01313
Power Source	24V DC
Alarm Current @24V DC	12mA
Standby Current	N/A
Ambient Temperature	-10°C ~ +55°C
Material	Fire-proof plastic
Color	White surface/ Red LED
Dimensions	70mm(H)x70mm(W)x15mm(D)
Weight	About 32g



Wiring Diagram

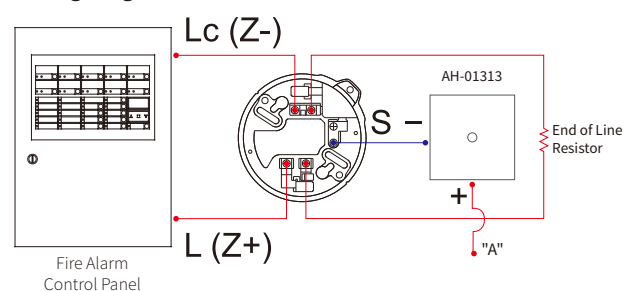



Vivid 32

Fire Alarm Control Panel

Characteristics

- Model range from 1 to 32 zones.
- AC power supply has passed EMI (Electromagnetic Interference).
- Each zone has a separate disable function.
- Double sets of sounder outputs.
- Long-term or temporary silencing feature.
- Microprocessor-base design.
- Zonal sounder circuit with supervision.
- LCD (24x2 lines) for events display and store capacity up to 255 events.
- Fire Relay Output contacts and Fault Relay Output contacts.
- Switch membrane provides longer service and is water-proof, dust resistant and easy to clean.

Specifications

Model	Vivid 32	
Power	220V AC, 50/60Hz *Others also available	
Battery Capacity	1~16 zone 24V/4 Ah	17~32 zone 24V/7Ah
Max. Output Current	2A @24V DC	
# of heat detectors connected	No limit *Except electronic-type	
# of smoke detectors connected	30/zone *Horing Lih manufactured	
Max. No. of Bells @25mA	40 per sounder circuit	
End of Line Resistor	4.7kΩ *One per zone	
Material	1.2mm steel plate	
Dimensions (H x W x D) mm	350 x 350 x 100 400 x 350 x 125 (with zone indication)	
Optional Features	Individual zone indication	



EN54 
pending

QA12 & 5-QA12

Fire Alarm Control Panel



5-QA12



QA12

Characteristics

- Alarm verification up to 7 seconds for real fire confirmation and avoid false alarm from environment interference.
- Zone test mode to perform alarm and fault functional test.
- Each zone has a separate disable function.
- Fault indications for wire disconnection, unstable AC power, battery short circuit or disconnection and internal PCB unplug.
- 5-QA12 only up to 5 zones, QA12 could up to 80 zones.

Specifications

Model	5-QA12	QA12
Power	220V AC, 50/60Hz *Others also available	
Battery Capacity	24V/4Ah	
# of heat detectors connected	No limit *Except electronic-type	
# of smoke detectors connected	30/zone *Horing Lih manufactured	
End of Line Resistor	10kΩ *One per zone	
Material	1.2mm steel plate	
Color	Pearl gray *Others also available	
Dimensions (mm) H x W x D	320 x 250 x 100	10 zone : 450 x 330 x 130 20 zone : 550 x 330 x 130 30 zone : 680 x 380 x 150 40 / 50 zone : 950 x 420 x 150 60 ~ 80 zone : 1300 x 420 x 170



AH-03312

Fire Alarm Control Panel



32 Zone

Characteristics

- Model range from 1 to 32 zones.
- AC power supply has EMI (Electromagnetic Interference).
- Each zone has a separate disable function.
- Double sets of sounder contacts.
- Automatic telephone dialer feature.
- Long-term or temporary silencing feature.
- Protection against voltage spikes up to 2.5KV.
- Microprocessor-base design.
- Sounder short circuit or disconnection detection.
- Fire Alarm NO, NC, COM and Fault NO, NC, COM output contact points.
- Fire Relay Output contacts and Fault Relay Output contacts.
- Switch membrane provides longer service and is waterproof, dust resistant and easy to clean.



Specifications

	32 Zone	8 Zone	4 Zone
Model	AH-03312-32L	AH-03312-8L	AH-03312-4L
Power	220V AC/50Hz *Others also available		
Battery Capacity	24V/12Ah	24V/7Ah	24V/4Ah
Max. Output Current	2A @24V DC		
# of heat detectors connected	No limit *Except electronic-type		
# of smoke detectors connected	30/zone *Horing Lih manufactured		
Max. No. of Bells @25mA	40 per sounder circuit		
End of Line Resistor	4.7kΩ *One per zone		
Material	1.2mm steel plate		
Dimensions	550mm(H) 400mm(W) 150mm(D)	370mm(H) 340mm(W) 135mm(D)	320mm(H) 250mm(W) 100mm(D)
Optional Features	LCD display (2x20) with simple function keypad		N/A



QP Series

Fire Alarm Control Panel



QP212



QP112



QP412

Characteristics

- Removable front board for easy maintenance.
- Easy-to-clean front board is able to avoid dirt attached.
- High luminance and long life span LED.
- Build-in 24V power and battery charger.
- Independent visual & audible indication for zone open/short fault.
- Independent visual & audible indication for AC power & battery fault.
- Visual & audible indication for sounder short circuit fault.
- Buzzer silence with 3-mode operation feature.
- Accurate supervision circuit for battery.
- Short circuit = Alarm feature (selected by JUMPER applicable for manual call point w/o resistance) Model. QP112
- Day/Night Mode Selection. (Model. QP212, QP412)
- System will back to normal automatically after alarm status is released. (Model. QP212, QP412)
- Ground fault detection feature. (Model. QP212, QP412)
- Fault Output (NO. NC. COM), Alarm Output (NO. NC. COM.), Zone Output. (Model. QP212, QP412)
- 24V DC power output for external load (Model. QP412)
- Zone EOL resistor can be set from panel board (Model. QP412)

Specifications

	1 zone	2 zone	4 zone
Model	QP112	QP212	QP412
Power	220V AC, 50/60Hz *Others also available		
Battery Capacity	24V /1.2Ah		
Max. Output Current	1 A	1.2 A	2.0 A
# of heat detectors connected	No limit *Except electronic-type		
# of smoke detectors connected	20/zone *Horing Lih manufactured		
End of Line Resistor	4.7 kΩ		
Material	1.2mm steel plate		
Dimensions (H x W x D) mm	203 x 272 x 71		



Multi-Hazard Suppression Systems



AH-03233

QSP-32



QSP-120 1 cross-zone



QSP-120 5 cross-zone

AH-03233 Releasing Indicator

- The display can be set according to customer's requirements.

QSP-32 Manual Pull Station

- Emergency Start/Stop switch, Auto/Manual key switch.
- Power LED, Releasing LED, Start LED, Stop LED, Auto LED, and Manual LED.
- Digital release countdown.

QSP-120 Multi-Hazard Suppression Control Panel

- Panel and manual pull station count-down simultaneously.
- Discharge delay timer setting (20~999 seconds).
- Cross-zone detection confirmation makes better stability.
- Built-in phone jacks on both panel and manual pull station.
- Expandable to 5 cross-zone detection sections.
- Each section has manual/auto operation mode.
- Wiring trouble inspection.
- Through dipswitch to select the supervision on feed-back signal of agent discharge.
- All 24V output contacts are protected by fuse.

Specifications

Model	AH-03233
Supply Voltage	24V DC 670mA (bulb) 310mA (LED)
Light Source	1W bulb x 18 or ø5 LED RED x 28
Display Type	Non-flash
Material	0.8mm stainless steel
Color	Red
Dimensions	155mm(H) x 405mm(W) x 60mm(D)



Specifications

Model	QSP-32
Supply Voltage	24V DC
Material	1.2mm stainless steel
Color	Red
Dimensions	160mm(H) x 165mm(W) x 50mm(D)



Specifications

Model	QSP-120
Power	220VAC 50/60Hz * others also available
Battery Capacity	1 cross-zone: 24VDC 4Ah 5 cross-zone: 24VDC 4Ah
Zone voltage	24VDC
EOL Resistor	4.7kΩ
Detection Type	Cross-zone detection
# of heat detectors connected	No limit *Except electronic-type
# of smoke detectors connected	25/zone *Horing Lih manufactured
Dimensions(mm)	1 cross-zone : 350 (H) x 400 (W) x 130 (D) 5 cross-zone : 550 (H) x 400 (W) x 130 (D)
Color	Ivory



Packing List

Model	Description	Packing	N.W(KG)	G.W(KG)	Measurement(mm)
QA16	1~4 loop with battery	1set/ctn	17.0	18.0	570×470×210
QA16	5~8 loop with battery	1set/ctn	24.0	26.0	650×550×200
QA01		100pcs/ctn	15.0	18.0	545×470×335
QA05		100pcs/ctn	15.0	20.0	545×470×335
QA06		100pcs/ctn	13.5	17.0	545×470×335
QA19	without base	60pcs/ctn	10.5	13.5	520×305×460
QA0817	without cover	100pcs/ctn	15.0	18.5	460×295×385
EDB01		10set/ctn	12.0	13.5	420×350×490
Q01-2	2-wire	100pcs/ctn	12.5	17.5	545×470×335
Q05-2	2-wire	100pcs/ctn	12.5	17.5	545×470×335
Q06-2	2-wire	100pcs/ctn	11.5	15.5	545×470×335
8011-2	2-wire	100pcs/ctn	12.5	17.5	545×470×335
AH-0715-2	2-wire	100pcs/ctn	12.5	17.5	545×470×335
8016-2	2-wire	100pcs/ctn	11.5	15.5	545×470×335
AH-0933	2-wire	100pcs/ctn	13.0	18.0	545×470×335
IR-0714	2-wire	100 pcs/ctn	13.0	17.5	550×440×330
IR-0814	2-wire	100 pcs/ctn	13.0	17.5	550×440×330
AH-0311-2	2-wire	100pcs/ctn	15.0	19.5	550×440×330
AH-0315-2	2-wire	100pcs/ctn	15.0	20.0	550×440×330
AH-0316-2	2-wire	100pcs/ctn	14.0	19.5	550×440×330
AH-0621-2	2-wire	100pcs/ctn	12.5	17.5	545×470×335
AH-0625-2	2-wire	100pcs/ctn	16.0	21.0	550×440×330
AH-0626-2	2-wire	100pcs/ctn	16.0	21.0	550×440×330
AH-9315	2-wire	100pcs/ctn	15.5	19.5	545×470×335
AHR-871	2-wire	100pcs/ctn	13.0	17.5	545×470×335
AH-9920	2-wire	100pcs/ctn	9.0	14.0	545×470×335
AH-0014	2-wire	100pcs/ctn	15.0	20.0	545×470×335
NQ12S		100pcs/ctn	14.0	19.0	550×440×330
NQ12BS		100pcs/ctn	14.0	19.0	550×440×330
NDKB1		100pcs/ctn	19.0	20.0	550×440×330
AH-0822	without adaptor	100pcs/ctn	13.5	19.0	545×470×335
NQ3F		100 pcs/ctn	12.5	17.0	470×545×335
NQ9F	Type 1	100pcs/ctn	15.0	20.0	550×440×330
NQ3S		100 pcs/ctn	12.5	17.0	470×545×335
NQ9S	Type 1	100pcs/ctn	16.0	21.0	550×440×330
QA31	Type 1	100pcs/ctn	15.5	20.0	550×440×280